

CFW701 HVAC-R Drives

Quick Setup Guide



CFW701 HVAC-R Drives

1 - Installation and Power Connections

Refer to CFW701 user guide chapter 3.

1.1 - Control Connections

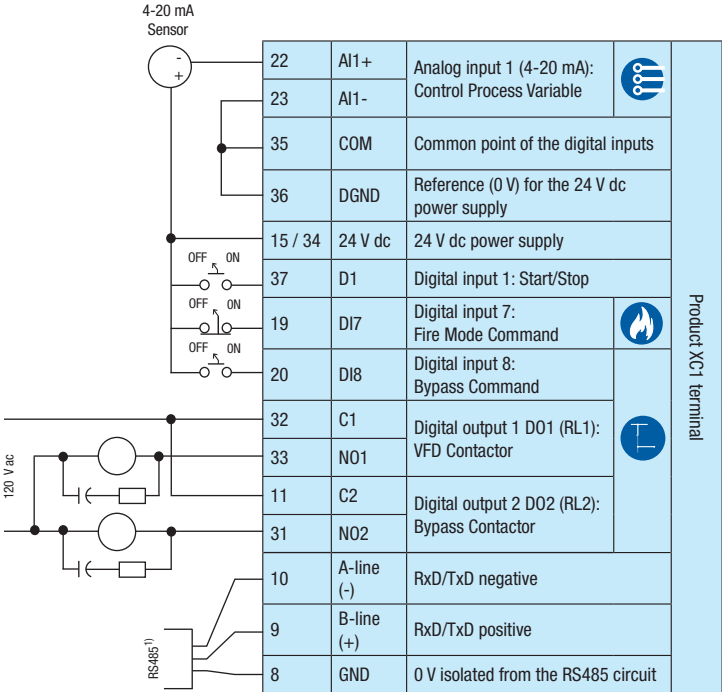

Note: 1) BACnet MS/TP, Metasys N2 and Modbus-RTU



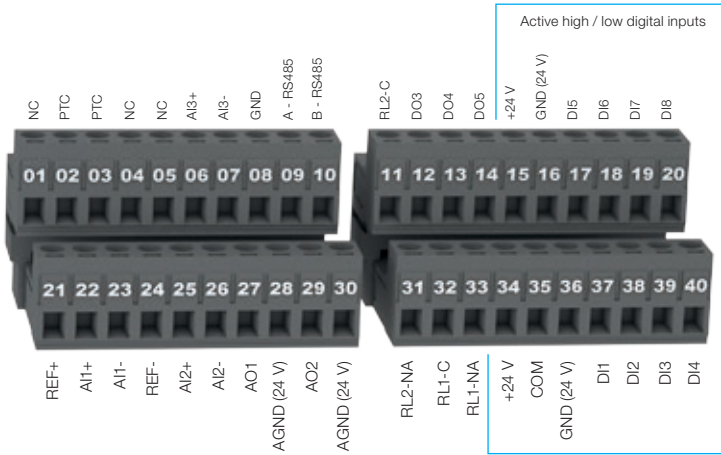

1.2 - Control Configuration

PROG	DEF	User	Description
2 - Wire start/stop			
P0000	0	5	Access to parameters
P0220	2	3	LOC/REM selection = LR key (REM when turn on CFW701)
Press  to select remote mode			
P0227	1	1	Remote run/stop = DIx
P0263	1	1	DI1 = start/stop
BACnet communication			
P0308	1	Δ	Serial address (0 to 255)
P0310	1	1	Serial baud rate - bits/s (0 = 9,600; 1 = 1,920; 2 = 38,400; 3 = 57,600)
P0311	1	0	Serial bytes (0 = 8 data bits, no parity, 1 stop bit)
P0312 ¹⁾	2	3	Serial protocol (2 = Modbus-RTU, 3 = BACnet MS/TP, 4 = N2)

Notes: Δ Setting depends on user/network.

1) Refer to the respective protocol manual for more details.



2 - Programming

2.1 - CFW701 Keypad

Back/ESC

- Return to monitoring mode
- Return to previous programming level

Up/Down

- Adjust speed in local mode
- Navigate through parameters



Enter/Menu

- Enter programming mode
- Use to select/save

Run

- Run in local mode

Stop

- Stop in local mode
- Reset

2.2 - Motor and Keypad Settings

2.2.1 - Oriented Startup Routine (STARTUP Group)



Press the ENTER/MENU

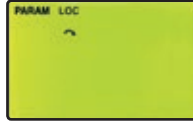

Select STARTUP



Press the ENTER/MENU



P0317 to "1"



PROG	DEF	User	Description
Oriented startup (scalar - V/F mode) - STARTUP group			
P0298	0	0	Normal duty
P0202	0	0	Control type V/F
P0401	-	■	Motor FLA (A)
P0403	60	■	Motor frequency nameplate data
P0402	1,710	■	Motor speed (RPM)

Note: ■ Set as per motor nameplate data.

PROG	DEF	User	Description
Basic application - BASIC group			
P0100	20s	Δ	Acceleration time (s)
P0101	20s	Δ	Deceleration time (s)
P0133	90 rpm	Δ	Minimum speed (Hz)
P0134	1,800 rpm	Δ	Maximum speed (Hz)

Note: Δ Setting depends on application.

PROG	DEF	Description
Motor overload settings - PARAM group		
P0156	1.05 x Inom-ND	Overload current at 105% speed
P0157	0.9 x Inom-ND	Overload current at 50% speed
P0158	0.65 x Inom-ND	Overload current at 5% speed

DEF	User	Description
Changing monitor display parameter - HMI group		
P0205 = 2 P0206 = 1	1	Speed reference (rpm)
	2	Output speed (rpm)
	3	Motor current (A)
	5	Output frequency (Hz)
	7	Output voltage (V)
	42	Time powered (h)
	44	Output energy (kWh)
	1011	Control setpoint 1
1015	Control process variable	

DEF	User	Description
Changing main display unit - HMI group		
P0209 = 3	3	rpm
	11	°C
	21	°F
	22	bar
	24	psi
	36	gal/s
	37	gal/min
	40	l/min
	50	m³/h

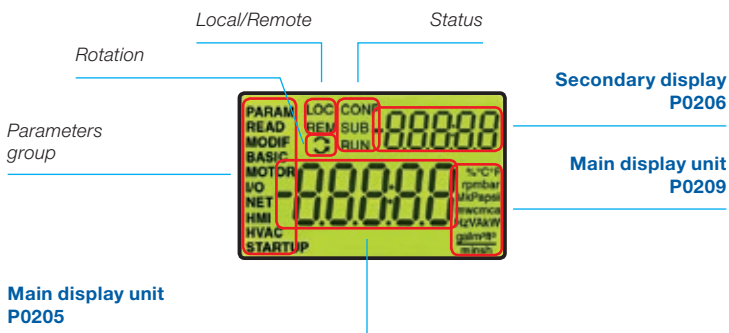

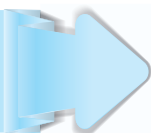

Fire Mode

This function makes the drive to inhibit its internal faults making the motor run at adverse conditions without stopping the process.



Alarm A211 will be generated on keypad when Fire Mode is enable.

PROG	DEF	User	Description
P0269 - DI7 function			
P0269	0	24	24 = Fire Mode
Set to Fire Mode with logic level "0" (0 V) at DI7			

P0580 - Fire Mode configuration			
P0580	0	Δ	0 = disabled (Fire Mode inactive)
			1 = enabled (keeps speed reference/PID setpoint)
			2 = enabled (set speed reference to maximum P0134)
			3 = enabled (set PID setpoint to the value programmed in P0581)
			4 = enabled (disables the output, motor will coast to stop)

P0581 - Fire Mode PID setpoint			
P0581	0	Δ	-32,768 to 32,767
Define the setpoint to be used by Fire Mode when the PID is enabled and P0580 = 3			

P0582 - Fire Mode Auto-Reset configuration			
P0582	0	Δ	0 = limited (as defined in P0340)
			1 = unlimited (every 1s)
Define Auto-Reset for critical fault: Overvoltage (F022), Overcurrent/Short-circuit (F070) and Safety Stop Relays (F160)			

P0340 - Auto-Reset time			
P0340	0	Δ	0 to 255s
Reset itself automatically after the time set in P0340 has elapsed			

Note: Δ Setting depends on application.



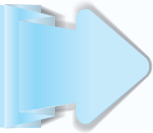

Bypass

Using one of its relay outputs the CFW701 allows the motor to be started cross the line. External circuit is needed for this operation.

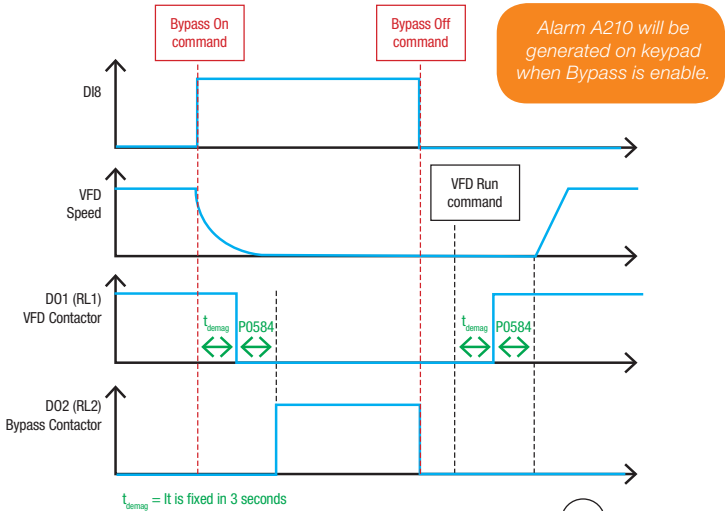

PROG	DEF	User	Description
P0270 - DI8 function			
P0270	0	23	23 = Bypass Mode
Set to Bypass Mode with logic level "1" (24 V dc) at DI8			

P0275 - D01 function (RL1) and P0276 - D02 function (RL2)			
P0275	13	39	39 = VFD contactor
P0276	2	40	24 = Bypass contactor

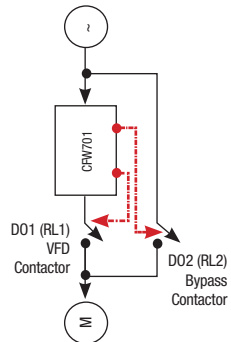

P0583 - Bypass Mode configuration			
P0583	0	1	0 = disabled (Bypass Mode inactive)
			1 = enabled by a digital input
			2 = enabled by a digital input or when a fault happens
Define the triggering event for the CFW701 entering the Bypass Mode			

P0584 - Bypass contactor time			
P0584	0.30s	Δ	Delay between the opening of one contactor and the closing of the other contactor (s)

P0320 - Flying start			
P0320	0	1	1 = flying start
The Flying Start function allows starting a motor that is spinning freely, accelerating it from the speed it is found.			

Note: Δ Setting depends on application.

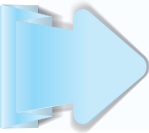

Dry Pump

Prevents the pump from running with no load.

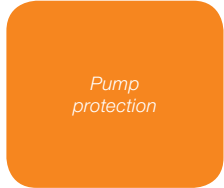

PROG	DEF	User	Description
Dry pump			
P0516	13	3	3 = rpm
P0517	1	0	Decimal point of engineering unit = xyzw
P1042	0	Δ	0 = disable
			1 = enable and generates only alarm (A0766)
			2 = enable and generates fault (F0767) ²⁾
P1043 ¹⁾	400	Δ	Motor speed for dry pump (rpm)
P1044	20	Δ	Motor torque for dry pump (%)
P1045	20s	Δ	Time delay for dry pump alarm (A0766) or fault (F0767) (s)

Notes: Δ Setting depends on application.

1) According to the selection of the engineering unit (P0516 and P0517 parameter).

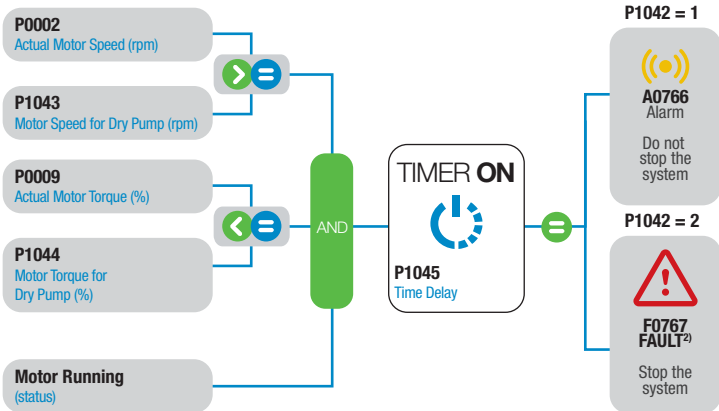

Note: 2) A0766 will be generated on keypad during motor deceleration and the fault F0767 after stopping the motor.

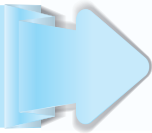

Broken Belt

Monitors motor torque and prevents VFD from running with no load in case of a broken belt.



PROG	DEF	User	Description
Broken belt			
P0516	13	3	3 = rpm
P0517	1	0	Decimal point of engineering unit = xyzw
P1046	0	Δ	0 = disable
			1 = enable and generates only alarm (A0768)
			2 = enable and generates fault (F0769) ²⁾
P1047 ¹⁾	400	Δ	Motor speed for broken belt (rpm)
P1048	20	Δ	Motor torque for broken belt (%)
P1049	20s	Δ	Time delay for broken belt alarm (A0768) or fault (F0769) (s)

Notes: Δ Setting depends on application.

1) According to the selection of the engineering unit (P0516 and P0517 parameter).

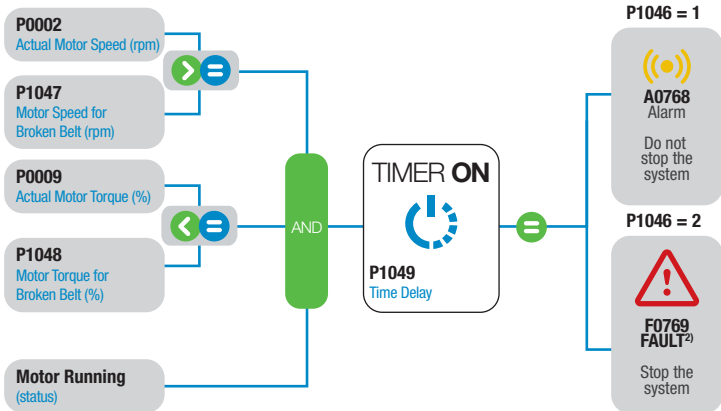

Note: 2) A0768 will be generated on keypad during motor deceleration and the fault F0769 after stopping the motor.

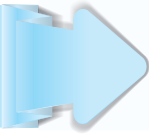

Filter Maintenance Alarm

Warns about the need to replace the filter.



PROG	DEF	User	Description
Filter maintenance			
P1050 ²⁾	0	Δ	0 = disable
			1 = enable and generates only alarm (A0770)
			2 = enable and generates fault (F0771) ¹⁾
P1051	5,000h		Filter maintenance time (0 to 32,000h)
P1052 ²⁾	Ready parameter		Operation time for filter maintenance

Notes: Δ Setting depends on application.

1) Set P1050 in "0" to reset the operation time for filter maintenance alarm.

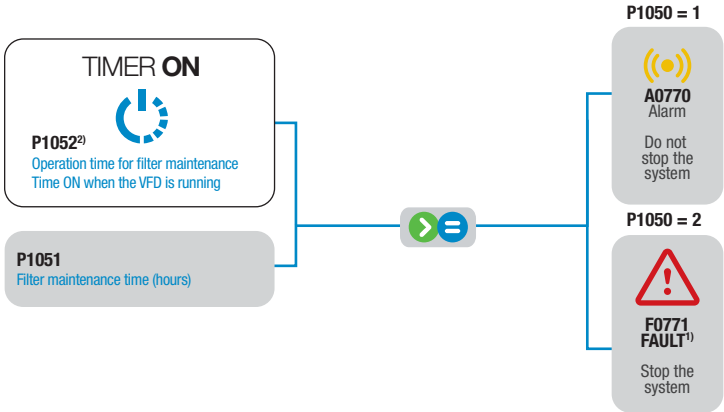

Notes: 1) A0770 will be generated on keypad during motor deceleration and the fault F0771 after stopping the motor.

2) Set P1050 in "0" to reset the operation time for filter maintenance alarm.

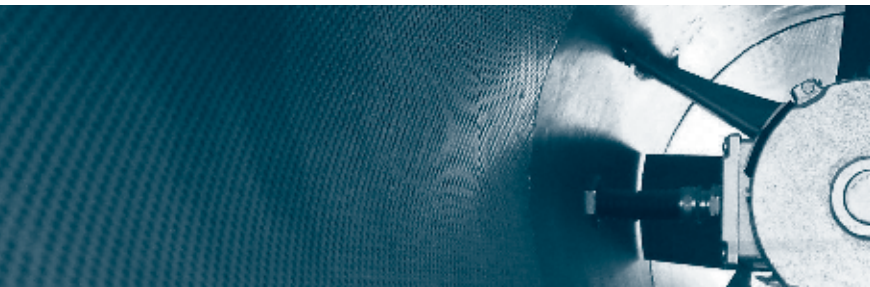



Short Cycle Protection

Prevents compressor/motor from being switched on and off in short period of times. Run/stop commands are ignored, with the exception of “general disable” and faults.



Compressor
function
protection

PROG	DEF	User	Description
Short cycle protection			
P0585	0	1	0 = disable 1 = enable
P0586	5s	Δ	Minimum run time (0 to 650.00s)
P0587			Minimum stop time (0 to 650.00s)

Note: Δ Setting depends on application.

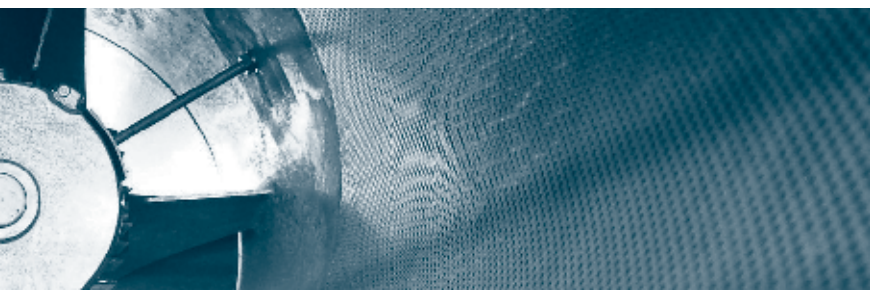
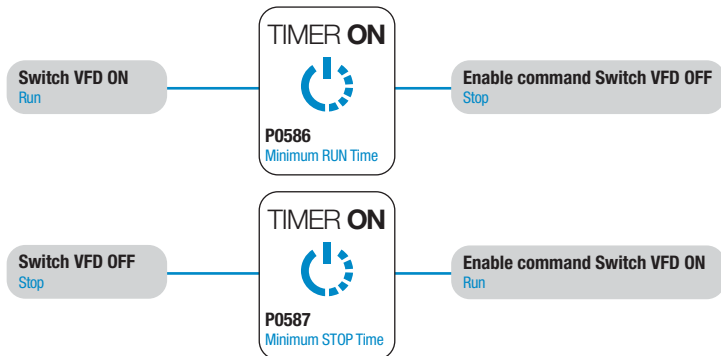

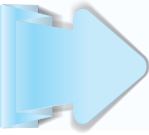

Energy Saving

Depending on the motor speed and load conditions, flux is reduced decreasing losses and therefore efficiency is improved.



Fans and pumps applications

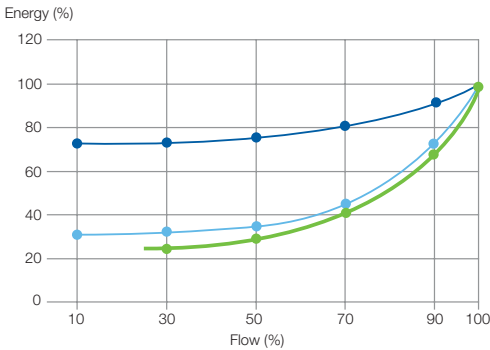

- Valve
- VFD
- CFW701 with energy saving enable

PROG	DEF	User	Description
Energy saving (V/F operation mode)			
P0407	0.68	■	Motor rated power factor
P0588 ¹⁾	0	60 ²⁾	Maximum torque (0 to 85%)
P0589 ³⁾	40	40 ²⁾	Minimum voltage level (40 to 80%)
P0590 ⁴⁾	600	360 ²⁾	Minimum speed (360 to 18,000 rpm)
P0591	10	10 ²⁾	Energy saving hysteresis

Notes: ■ Set as per motor nameplate data.

1) Set to 0% disables the energy saving function.

2) Recommended value. Other values can be used depending on the application and the motor.

3) Avoid the motor stalling.

4) The hysteresis for the minimum speed level is 2 Hz.



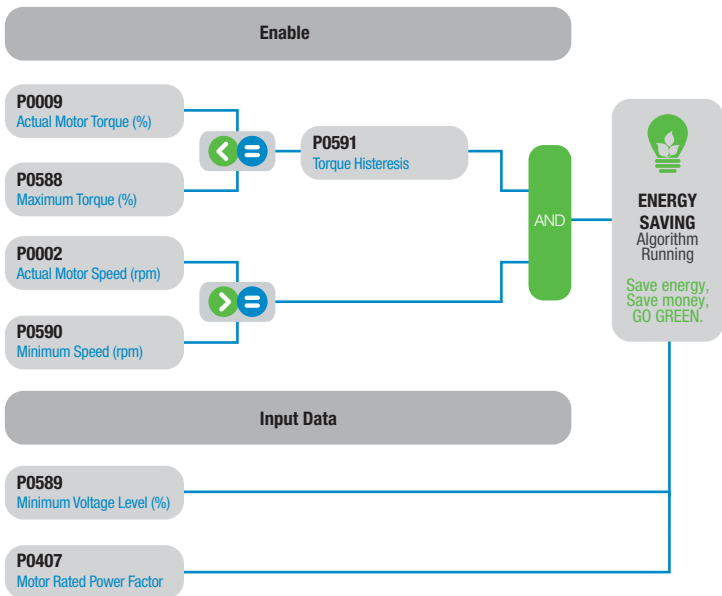

System Configuration

PROG	DEF	User	Description
Changing monitor display parameter - HMI group			
P0205	2	1015	Control process variable
P0206	1	1011	Control setpoint 1
P0209	3	Δ	21 = °F; 22 = bar; 24 = psi; 36 = gal/s; 37 = gal/min; 40 = l/min; 50 = m³/h

Note: Δ Setting depends on application.

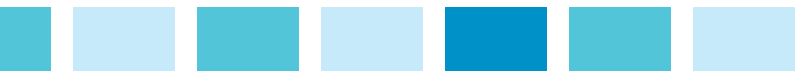

PROG	DEF	User	Description
Control connections			
P0222	1	7	Remote reference = AI1
P0231	5	5	AI1 signal function = main PID
P0233	0	1	AI1 = 4 - 20 mA

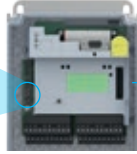
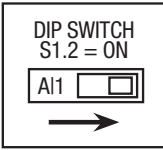

Process variable - engineering unit			
P0510	24	Δ	21 = °F; 22 = bar; 24 = psi; 36 = gal/s; 37 = gal/min; 40 = l/min; 50 = m³/h
P0511	1	1	Decimal point of engineering unit = wyw.z

Setpoint			
P1011 ¹⁾	0	Δ	Setpoint by HMI

PID controller			
P1017	0	Δ	0 = disable PID / 1 = Direct / 2 = Reverse
P1020 ²⁾	1		PID proportional gain
P1021 ²⁾	0.430		PID integral gain
P1022 ²⁾	0		PID derivative gain

Examples of applications:

- Pump
 - Direct: increase the pressure, increase the pump speed
- Cooling tower
 - Reverse: increase temperature, decrease fan speed

	Process variable	VFD speed
Direct	↓	↓
	↑	↑
Reverse	↓	↑
	↑	↓

Sensor scale			
P1027 ¹⁾	0	Δ	Sensor minimum level (%)
P1028 ¹⁾	1000		Sensor maximum level (%)

Notes: Δ Setting depends on application.

1) According to the selection of the engineering unit (P0510 and P0511 parameter).

2) Only change these parameters if it is necessary to improve the system response.

Important: CFW701 offers two (AI2 and AI3) external PID Controllers for use to control independent process variables (it might be for the control of external process not related to what the main PID loop is handling). This discards the use of an additional PID controller. Refer to CFW701 programming manual chapter 19.9 and 19.10 for further information.

System Protection

PROG	DEF	User	Description
Alarm or fault configuration			
P1030	0	Δ	0 = disable
			1 = enable and generates only alarm (A0760 and A0762)
			2 = enable and generates fault (F0761 and F0763) ³⁾

Low level protection (example broken pipe for pumps)			
P1031 ¹⁾	50	Δ	Value for low level alarm/fault for the control process variable
P1032 ²⁾	5s		Time delay for low level alarm/fault for the control process variable (s)

High level protection (example pipe obstruction for pumps)			
P1033 ¹⁾	900	Δ	Value for high level alarm/fault for the control process variable
P1034 ²⁾	5s		Time delay for high level alarm/fault for the control process variable (s)

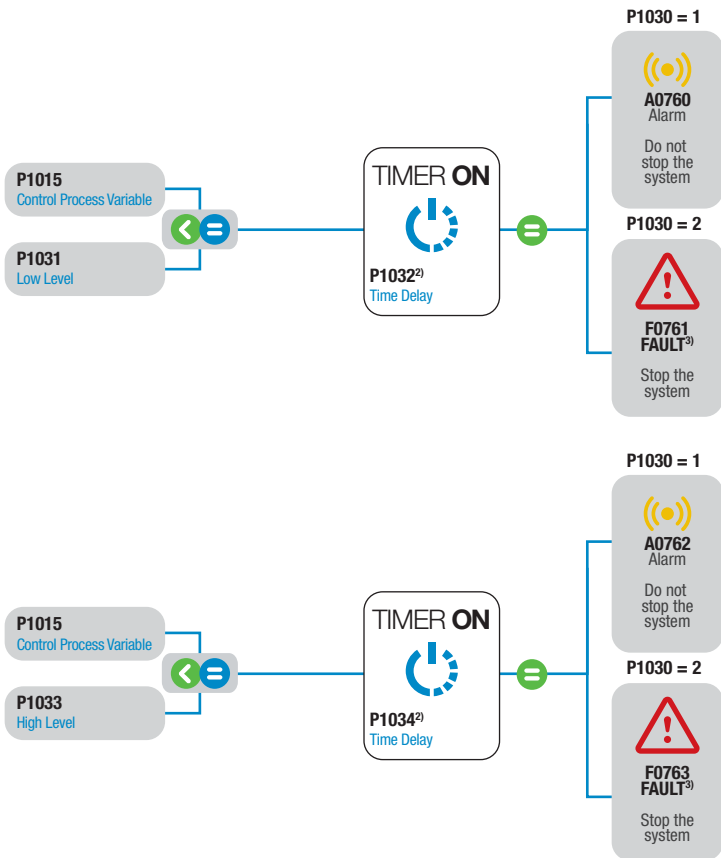

Notes: Δ Setting depends on application.

1) According to the selection of the engineering unit (P0510 and P0511 parameter).

2) Value in 0.00s disables the protection.

3) A0760/A0762 will be generated on keypad during motor deceleration and the fault F0761/F0763 after stopping the motor.

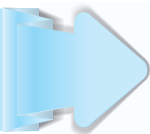

Sleep / Wake-Up Mode

Prevents the operation of the motor at low speeds for a amount of time programmed. Wake-up mode determines the time the drive is restarted.



PROG	DEF	User	Description
Engineering Unit 4			
P0516	13	3	3 = (rpm)
P0517	1	1	Decimal point of engineering unit = wyw.z
Sleep Mode			
P1036 ¹⁾	350	0	Motor speed below which CFW701 goes to Sleep Mode (rpm)
P1037	5s	Δ	Time delay for CFW701 goes to Sleep Mode (s)

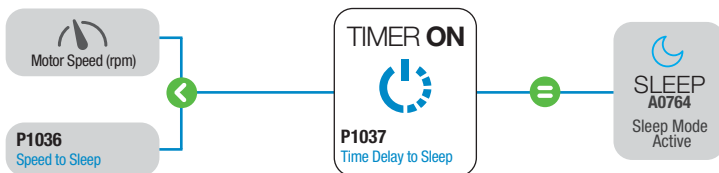

PROG	DEF	User	Description
Wake-Up Mode			
P1038 ²⁾	5	Δ	Control process variable deviation for CFW701 goes to Wake-Up (%)
P1039	10s		Time delay for CFW701 goes to Wake-Up mode (s)

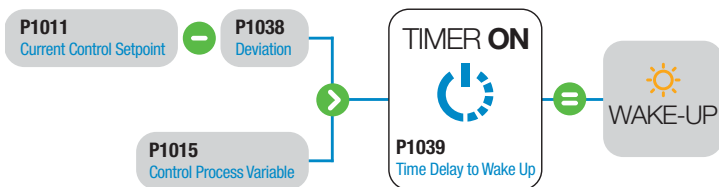

Notes: Δ Setting depends on application.

1) According to the selection of engineering unit (P0516 and P0517 parameter).

2) Value in 0.0% disables the sleep mode.

